



PS40-EX Stock No. 1350402

CUL, UL and CSEFM Listed, FM Approved and NYMEA Accepted
Dimensions: 6" x 7"H (15,2cm x 17,8cmH)
Enclosure: Cast Aluminum
Pressure Connection: 1/2" NPT Male Brass Fitting
Conduit Entrance: 1/2" NPT female conduit opening
Factory Adjustment: One switch operates on decrease at 30 PSI (2,1 BAR) and one switch operates on increase at 50 PSI (3,5 BAR).
Pressure Range: 10 - 175 PSI (0,7-12,1 BAR)
Maximum Differential: Approx. 2 lbs. at 20 PSI (0,14@1,4 BAR)
5 lbs. at 175 PSI (0,35@12,1 BAR)
Maximum System Pressure: 250 PSI
Switch Contacts: Two sets of SPDT (Form C)
15.0 Amps at 125/250 VAC
2.0 Amps at 30 VDC

Environmental Specifications:

For use in hazardous locations classified as:

Class I: Groups B, C, D, Div. 1

Class II: Groups E, F, G, Div. 1

Class III: Div. 1

NEMA 4 and 9 Rated Enclosure

Temperature range: -40°F to 140°F (-40°C to 60°C)

Service Use:

Automatic Sprinkler NFPA-13

National Fire Alarm Code NFPA-72

The PS40-EX is designed as a pressure type supervisory switch. The NFPA 72, National Fire Alarm Code, requires that a low pressure signal is sent at 10 psi below normal air pressure and 10 psi above normal pressure on dry pipe valves. Therefore, the PS40-2A switches are factory set for a pressure decrease at 30 psi and a pressure increase at 50 psi with a normal air pressure of 40 psi. The switches are adjustable at any point between 10 and 175 psi.

Installation And Test Procedures

Mounting: The device should be mounted in the upright position (threaded connection down). Only teflon tape should be applied to the male threads. Using pipe joint cement or pipe thread compound (pipe dope) could obstruct the device and cause it to not work properly.

In outdoor applications, a NEMA type 4 conduit hub should be installed. If the pressure needs to be adjusted from the factory settings, adjust the system pressure to the desired trip point. Use a ohm meter on the appropriate contacts (COM and NC for pressure decrease and COM and NO for pressure increase). Adjust the knurled knob until the meter indicates continuity. At that point the switch is set for that particular pressure. When the adjustments are complete, raise and lower the system pressure to ensure the switch is properly set.

On dry systems, connect the PS40-EX in the air supply line on the system side of any shutoff and check valves.

Provisions for testing the unit without affecting the entire system can be accomplished with the installation of a Potter Bleeder Valve (Model BVL) in the line to the PS40-EX.

Testing: The operation of the pressure supervisory switch should be tested upon completion of installation and periodically thereafter in accordance with the applicable NFPA codes and standards and/or the authority having jurisdiction (manufacturer recommends quarterly or more frequently).

CAUTION

Testing the PS40-EX may activate other system connected devices.

Ordering Information

Model	Description	Stock No.
PS40-EX	Pressure switch with two sets SPDT contacts	1350402
BVL	Bleeder Valve	1000018
	Hex Key	5250073

Typical Sprinkler Application - Dry System

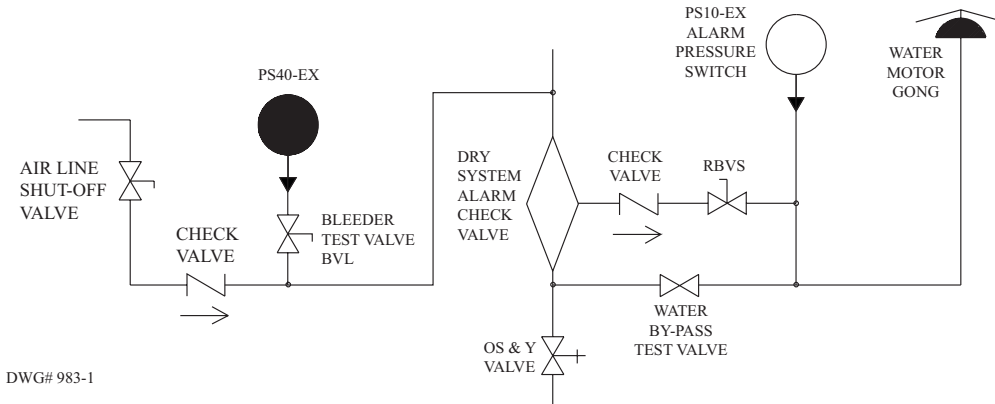

Typical Electrical Connections

Low Air Only

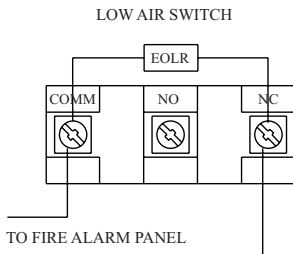

Low and High Air on the Same Zone

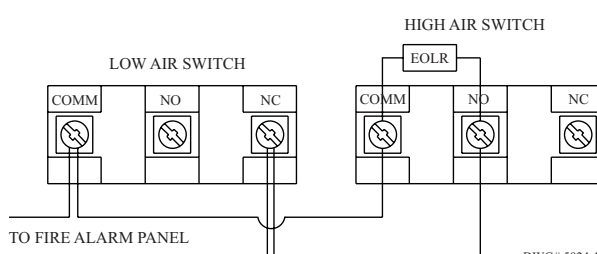

Note: High switch changes with pressure increase. Low switch changes with pressure decrease.

Switch Terminal Connections Clamping Plate Terminal

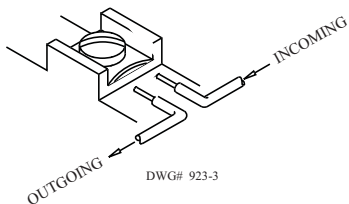

⚠ CAUTION

An uninsulated section of a single conductor should not be looped around the terminal and serve as two separate connections. The wire must be severed, thereby providing supervision of the connection in the event that the wire becomes dislodged from under the terminal.

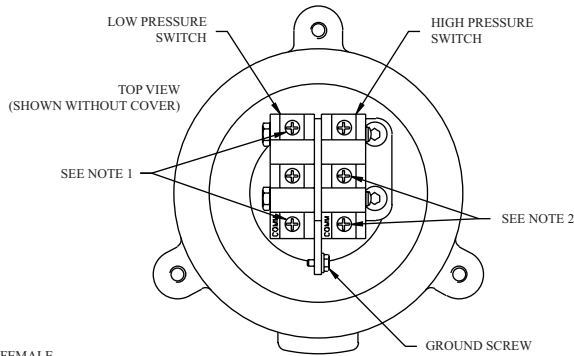

1/2" NPT FEMALE CONDUIT OPENING

- NOTES:
1. THESE CONTACTS CLOSE ON A PRESSURE DECREASE.
2. THESE CONTACTS CLOSE ON A PRESSURE INCREASE.

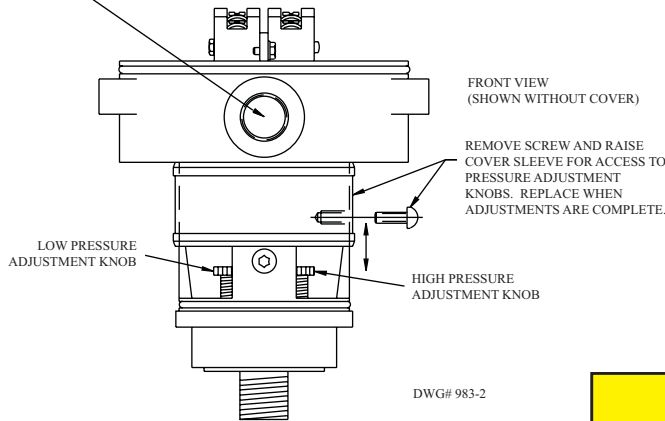

DWG# 983-2

WARNING

Use of pipe joint cement may result in obstruction of aperture and loss of signal.

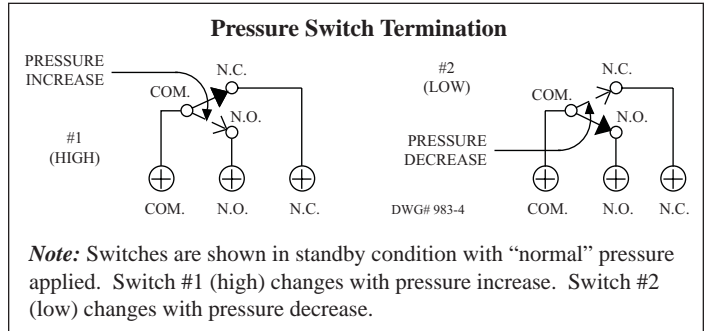

Note: Switches are shown in standby condition with "normal" pressure applied. Switch #1 (high) changes with pressure increase. Switch #2 (low) changes with pressure decrease.

Field Adjustments

The operating point of the switches on the PS40-EX can be adjusted to any point between 10 and 175 PSI (0,7-12,1 BAR) by turning the adjustment knob(s) clockwise to raise the actuation point, and counter-clockwise to lower the actuation point. The two switches operate completely independently of one another, and each switch may be adjusted to actuate at any point the system requires. Final adjustment should be made with a pressure gauge.

Note: To prevent leakage, apply teflon tape sealant to male threads only.

CAUTION

When this device is to be installed in an area that is classified as "HAZARDOUS", the person responsible for safety in the area should be contacted to determine if the tools and operations required for the installation of the device and associated components are permitted in the area. To reduce the risk of ignition of hazardous atmospheres, disconnect supply circuits before opening cover. Keep cover tight while circuits are live. Cover screws must be torqued to 45-50 in. lbs (5,1 - 5,7 n-m).

Engineer/Architect Specifications

Air pressure supervisory switch shall be a Model PS40-EX as manufactured by Potter Electric Signal Co. of St. Louis, Mo. and shall be installed on the sprinkler systems as shown on the drawings and/or as specified herein.

Switches shall be provided with a 1/2" NPT male pressure connection to be connected into the air supply line on the system side of any shut-off valve. A Model BVL bleeder valve as supplied by Potter Electric Signal Co. of St. Louis, Mo. or equivalent shall be connected between the air line to provide a means of testing the operation of the supervisory switch.

The switch unit shall contain SPDT (Form C) switches. One switch shall operate at a pressure decrease of 10 PSI (0,7 BAR) from normal. The second switch shall operate at a pressure increase of 10 PSI (0,7 BAR)

from normal. Switch contacts shall be rated at 15.0 Amps at 125/250 VAC and 2.0 Amps at 30 VDC. The units shall have a maximum pressure rating of 250 PSI (17,2 BAR) and shall be adjusted from 10 to 175 PSI (0,7 - 12,1 BAR).

The switch housing shall be weatherproof and oil resistant with a NEMA 4 rating. The cover shall incorporate tamper resistant screws.

The unit shall be listed by Underwriters Laboratories, Inc. and CSFM and approved by Factory Mutual. It shall be rated for use in hazardous locations classified as Class I, Groups B, C, D, Div. 1; Class II, Groups E, F, G, Div. 1; Class III, Div. 1.