

Harrington Signal Inc.
 2519 4th Avenue, Moline, Illinois 61265
 P.O. Box 590, Moline, Illinois 61266-0590
 Phone: (800) 577-5758 Local: (309) 762-0731 Fax: (309) 762-8215
 Internet: www.harringtonfire.com



ISO 9001 Certified Management System

Description

Harrington Signal Inc. Model ASHX PowerTone® Explosion-proof Amplified Speaker is designed for use in hazardous locations. The unit produces a crisp, clear, high-decibel tone. The tone may be generated by the PowerTone® Signaling System or by a compact, solid-state, plug-in card.

The speaker cone and projector are made of spun aluminum. The speaker driver, circuitry and tone card are contained in an explosion-proof housing. An internal gain control allows for volume adjustment. The amplified speaker is Listed for indoor and outdoor use, is NEMA 3 rated, and is finished in red enamel.

PowerTone® Model ASHX Amplified Speakers operate at 24 VDC and are polarized for connection to system supervised alarm notification circuits.

Application

The PowerTone® Amplified Speaker is well suited for signaling in hazardous areas with high ambient noise levels and where a unique audible signal is required. The amplified speaker is designed for locations where the danger of explosion or fire exists.

The speaker is suitable for use in National Electrical Code (NFPA 70): Class I, Groups B, C, D, Division 1 hazardous locations. When used in conjunction with the PowerTone® Signaling System and PTCK25 connector card, the speaker can produce multiple tones for various signal requirements. For single tone applications the PowerTone® Signaling System or universal tone card may be used. The speaker may be used with any compatible 25 or 70Vrms audio system by using the PTCK25 or PTCK70 connector card. The speaker can be indoor or outdoor mounted. The ASHX is NEMA 3 rated.



Features

- 24 VDC polarized operation.
- UL sound pressure level. (see chart)
- Multiple tone capability (with PowerTone® System & PTCK).
- Wide selection of tones (universal tone cards).
- Voice capable with PTCK audio interface card.
- Spun aluminum cone and projector.
- Rugged explosion-proof circuitry housing.
- Internal gain control.

Ordering Information

Model Number	Part Number	Description
ASHX-24SMR	ASHX-24SMR	Amplified Speaker, 24VDC or 25/70 VRMS, Red
PT25W24	PT25W24	PowerTone System
		C/O: PowerTone Module (PTBD)
		Alarm Indicating Mini-Module, 2 circuit (5130 107)
		Plate Kit w/ insulator and hardware (PTPLATE)
PTBD	PTBD	PowerTone Module
U-TC	U-TC	Universal Tone Card - Field Selectable to Desired Tone
PTCK25	PTCK25	25Vrms Connector Card - connects amplified spkrs to 25Vrms audio sys.
PTCK70	PTCK70	70Vrms Connector Card - connects amplified spkrs to 70Vrms audio sys.
ULFB2	ULFB2	UL Listed box (11" x 15" x 4")

Tone Card Sound (Model UTC)			Audible Frequency (Hz)	Repetition rate (cycles/min)	Audibility	
Selection	Name	Description			dB(A) Sound Power	UL dB(A) Sound Pressure
TM1	Wail	Conventional siren	550-1250	11	117.3	96.7
TM2	Yelp	Rapid siren	550-1250	3.3 Hz	117.4	96.8
TM3	Hi-Lo	Alternating high and low	560 and 760	50	116.3	95.7
TM4	Bell	Bell, struck repeatedly	800	50	114.1	93.5
TM5	Yeow	Descending high to low, repeated	1300 and 550	36	117.3	96.7
TM6	Horn	Steady horn	470	Continuous	112.2	91.6
TM7	Beep	Slow intermittent horn	470	50	111.1	90.5
TM8	Stutter	Rapid intermittent horn	470	5	111.4	90.8
TM9	Slow Whoop	Slow ascending, low to high – repeated	420 and 1160	15	115.9	95.3
TM10	Temporal Slow Whoop	NFPA coded slow whoop (fire alarm use only)	420 and 1160	15	113.0	92.4
Connector card model			Rated voltage			
PTCK25			25 VRMS		107.9	93.3
PTCK70			70 VRMS		107.4	92.8

Specifications

Alarm notification appliances shall be explosion-proof amplified speakers using solid-state circuitry. The amplified speakers shall operate at 24 VDC and be polarized for DC supervision. The unit shall be designed for use in hazardous locations/explosion-proof locations. The amplified speaker driver and circuitry shall be contained in an explosion-proof housing. The amplified speaker shall be NEMA 3 rated. The speaker cone and projector shall be of spun aluminum. The entire unit shall have a red finish. The amplified speakers shall be capable of clearly reproducing any number of HSI tones. The tones shall be selectable by connection to a PowerTone® Signaling System using a PTCK25 connector card (for single or universal tone card (for single tone). The amplified speakers shall be compatible with any 25 or 70Vrms audio system using the PTCK25 or PTCK 70 connector card. The amplified speakers shall have an internal gain control for tone output adjustment. The amplified speakers shall be capable of indoor or outdoor mounting. The amplified speakers shall be suitable for use in National Electrical Code (NFPA 70); Class I, Groups B, C, and D, Division 1 hazardous locations. The amplified speakers shall be capable of a UL sound pressure level at 10 feet of 97dB(A). The speakers shall be UL Listed for fire alarm signaling use. Alarm notification appliances shall be Harrington Signal Inc Model ASHX PowerTone® amplified speakers.

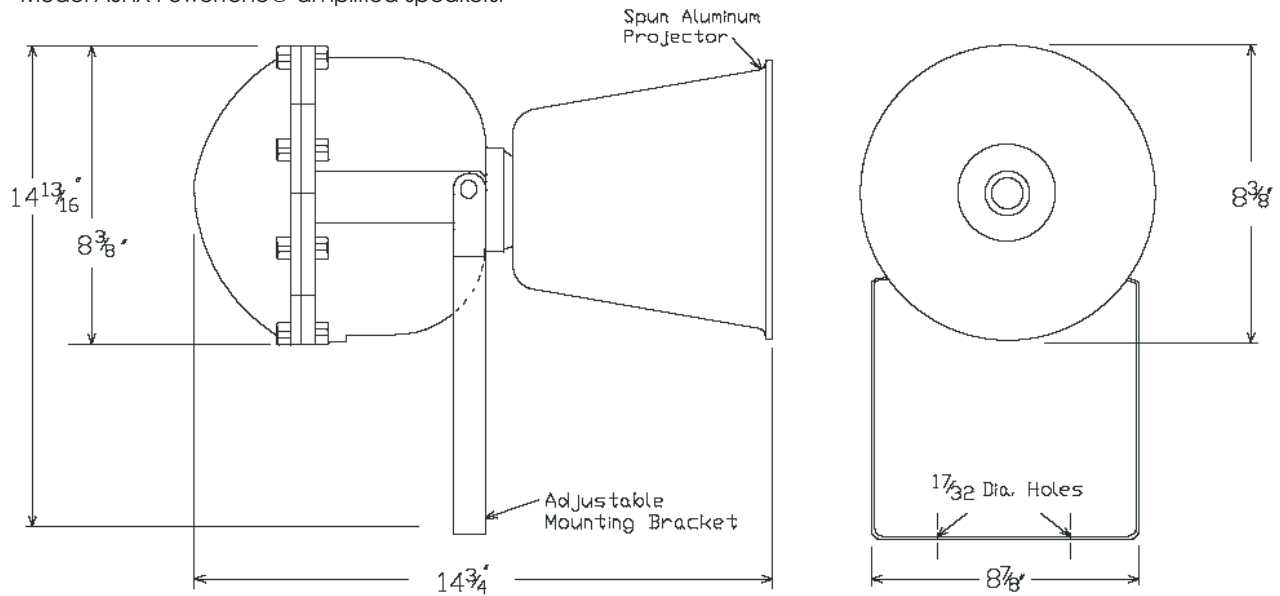

NOTICE: The information contained in this document is intended only as a summary and is subject to change without notice. The devices described in this document have specific instruction sheets which cover various technical, limitation and liability information. Copies of these instruction sheets and the General Product Warning and Limitations Document, which also contains important information are provided with the product and are available from Harrington Signal Inc. Fire Alarm. Information contained in these documents should be consulted before specifying or using the product. For further information or assistance concerning particular problems contact Harrington Signal Inc. Harrington Signal Inc. Fire Alarm reserves the right to change specifications without notice.