

The HD Series High Impact Domes are hammer tough, weathertight, and input power protected. The exterior, is comprised of a thick anodized CNC machined aluminum base, an impact resistant polycarbonate dome, and an anodized retaining ring that locks the dome in place while providing continuous rigidity against impact forces. The interior incorporates a voltage regulator board that allows 12 VDC or 24 VAC operation while providing protection from over voltage, transient spikes and improper electrical installations. Standard configuration includes an aluminum color base, clear dome with black inner sleeve, and choice of black and white or color camera.

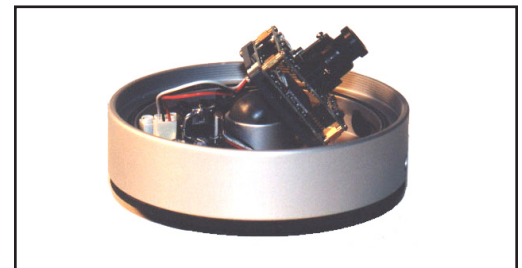

The HD Series is designed to mount over a single gang box to provide a flush appearance while leaving room inside the electrical box for installing modulators, power supplies, telemetry or video storage devices. The impact resistant dome can also be surface installed in minutes to all interior and exterior walls and ceilings.

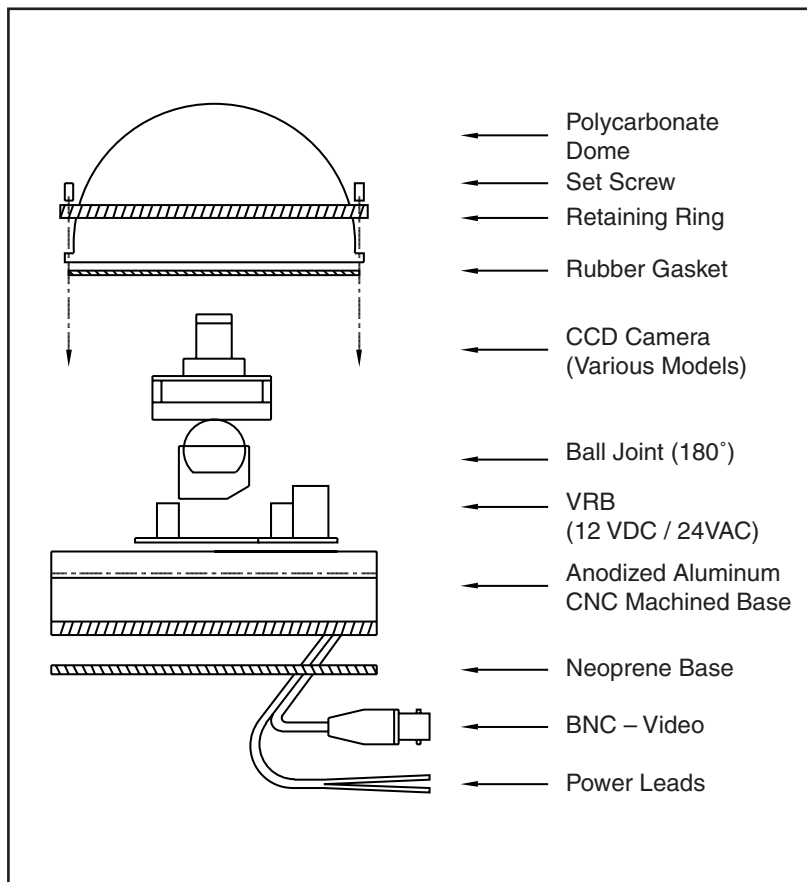

Above and left: The HD Series is based on a tough vandal resistant design comprising of a polycarbonate dome and anodized CNC machined base. The HD Series is extremely versatile for indoor and outdoor installations in vandal prone locations. It can also fit over a single gang electrical box for integration with cable television modulators and other electronic options. The HD Series is available in B&W and DSP color.

Applications:

- Schools / Prisons
- Access Control
- Home Automation
- Transit Vehicles
- Public Buildings
- Industrial Buildings
- Indoor / Outdoor

Specifications

Model	Color	B&W
TV System	NTSC	EIA
Image Sensor	1/3" CCD Color DSP Image Sensor	1/3" CCD Sony Image Sensor
Video Signal Output	1 V p-p, 75 ohm	1 V p-p, 75 ohm
CCD Effective Pixels	510 (H) x 492 (V) – NTSC	510 (H) x 492 (V)
Sync. System	Internal	Internal
Min. Illumination	1 lux @ F2.0	0.1 lux @ F2.0
Resolution	380 TV lines	420 TV Lines
S/N Ratio	>48 dB	>50 dB
Electronic Shutter	1/60 to 1/100,000	1/60 to 1/100,000
Gamma Correction	0.45	0.45
Backlight Compensation	Automatic	Manual Switch
Gain Control	AGC	AGC
Operational Range	-40°C to +50°C (-40°F to 122°F)	-40°C to +50°C (-40°F to 122°F)
Humidity Range	Up to 85% relative humidity	Up to 95% relative humidity
Power Supply	12VDC or 24VAC	12VDC or 24VAC
Power Draw	220 mA (Max.)	100 mA (Max.)
Lens Options	3.6mm, 6mm, 8mm, 12mm	3.6mm, 6mm, 8mm, 12mm
Dome	Polycarbonate (clear with inner sleeve)	Polycarbonate (clear with inner sleeve)
Base / Ring	CNC Aluminum Anodized (6061 T6)	CNC Aluminum Anodized (6061 T6)
Dimensions	4.63" (118 mm) dia / 3.31" (76 mm) H	4.63" (118 mm) dia / 3.31" (76 mm) H
Weight	1.0 lbs (454g)	1.0 lbs (454g)

Model Numbers:

Model	Description
HDB4236AC	B&W, 420 lines — 3.6mm lens (70° FOV)
HDB4206AC	B&W, 420 lines — 6mm lens (45° FOV)
HDB4208AC	B&W, 420 lines — 8mm lens (33° FOV)
HDB4212AC	B&W, 420 lines — 12mm lens (23° FOV)
HDC3336AC	Col, 330 lines — 3.6mm lens (70° FOV)
HDC3306AC	Col, 330 lines — 6mm lens (45° FOV)
HDC3308AC	Col, 330 lines — 8mm lens (33° FOV)
HDC3312AC	Col, 330 lines — 12mm lens (23° FOV)

24 VAC Plug-in Transformer:

PS2420 120 VAC to 24 VAC, 20VA, 60Hz

Features

- Weather and impact protected housing
- Vandal resistant / Hammer tested
- Rustproof anodized aluminum base
- Silver finish base / clear dome with black inner sleeve
- Universal 180° camera rotation
- B&W or color DSP
- Compact at only 4.6" diameter
- Neoprene backing / Dustproof
- 12VDC or 24VAC operation
- 3-year warranty

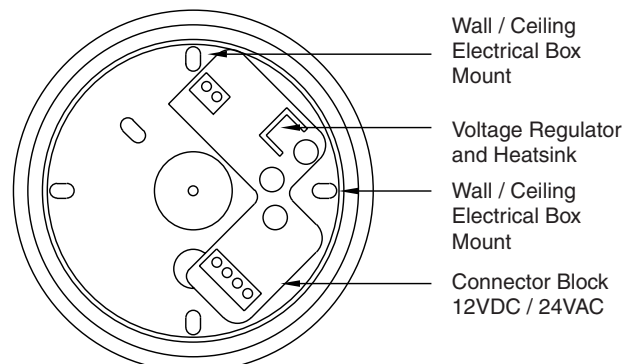
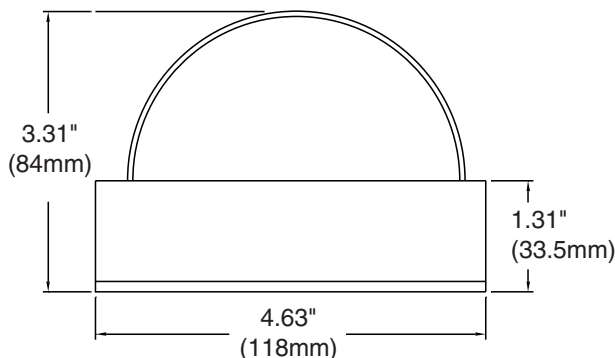

INTERNATIONAL SPACE OPTICS, S.A.

Address: 200 McCormick, Costa Mesa, CA 92626 USA

Phone: (800) 654-5367 (949) 260-1599 • Fax: (800) 828-2031 (949) 260-1594

E-mail: rainbow@isorainbow.com • Internet: www.rainbowcctv.com

©2005 International Space Optics — 1118-U0609

Technology by Derwent Extreme

Non metric weights and measurements are approximate. Specifications are subject to change without notice.